

C Series



ESA S640
CNC Control Unit
15" Color Touch
2D Graphic Screen

Standard Features

1. **Y1,Y2,X,R** CNC 4 Axes
2. **310mm Stroke, 410mm Throat Depth**
3. **ESA S640** CNC Control Unit
4. $\pm 0,03$ accuracy SERVO motorized back gauge. X=750mm, R=250mm
5. Quick clamp Promecam punch tool holder
6. **Sliding front sheet support arms**
7. Manuel Anti-deflection crowning with original Wila wedges.
8. MVD special narrow bottom table (European type)
9. GIVI optic linear scales
10. Standard punch tools (H: 67, 85°, R:08)
11. Standard die tools (60x60mm, 4 Vee V=16-22-35-50mm, 85°, H:60)
12. LED illumination on RAM

Optional Features

1. X+R to 4-6-8 axis back gauge options
2. Rolleri Rol200 hydraulic punch clamping
3. Wila hydraulic punch clamping
4. Wide bottom table for Multi Vee dies.
5. Motorized Anti-deflection crowning with original Wila wedges
6. 1.000mm X axis travel
7. AKAS or DSP front laser safety systems
8. Additional back gauge fingers
9. Front laser safety



Standard

X+R Axes Back Gauge



Standard

Manual Crowning

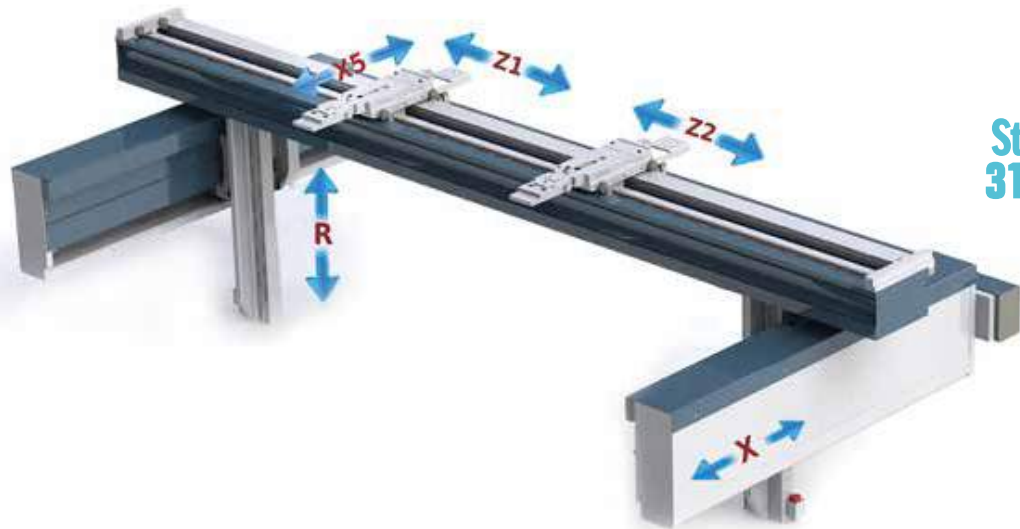

410 mm Throat

Stroke 310 mm

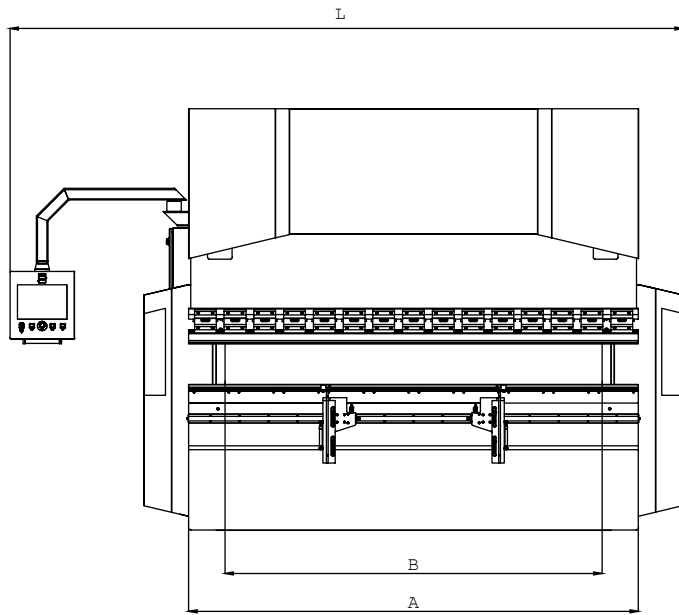
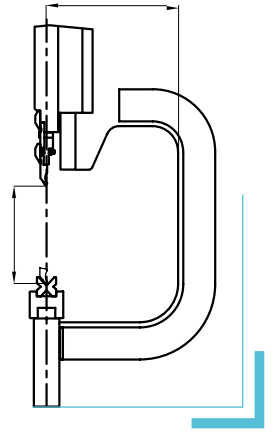

Front view

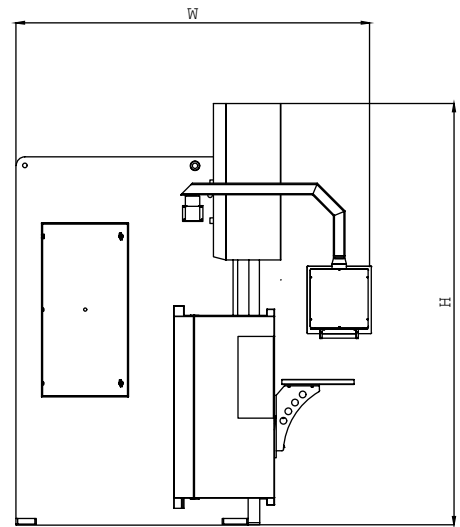

Side view

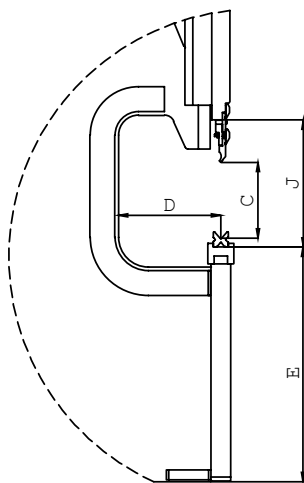

Work zone detail

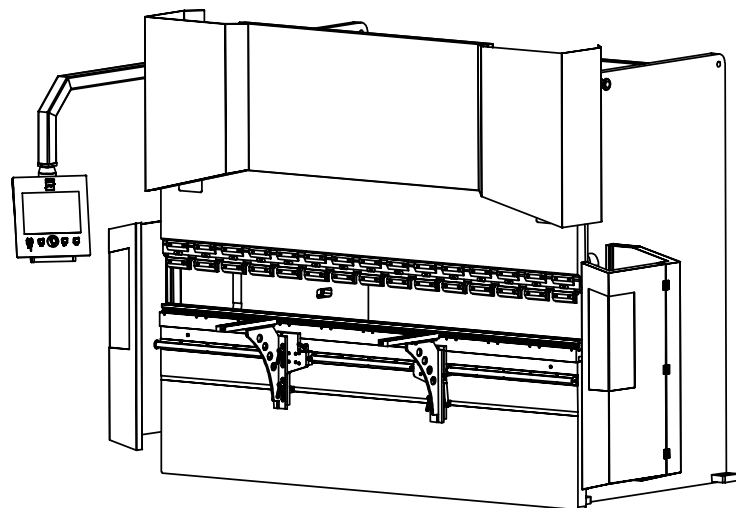

Perspective view

C-Series - Technical Specifications

C Bending Force	Bending Length	Distance between columns	Stroke	Daylight	Throat	Table Height	Machine Dimensions			Speed			Oil tank	Weight	Main motor
	A	B	C	J	D	E	Length x Width x Height (L x W x H)			Approach Speed	Return Speed	Bending Speed	Lt	kg	kW
	mm	mm	mm	mm	mm	mm	mm			mm/s	mm/s	mm/s			
C100	2600	2150	310	515	410	890	4220	2230	2950	200	135	10	180	6950	7,5
	3100	2600	310	515	410	905	4670	2230	2950	200	135	10	180	7300	7,5
C135	3100	2600	310	515	410	935	5150	2650	2950	210	130	10	180	8350	11
	3700	3200	310	515	410	945	5750	2650	2950	210	130	10	180	10000	11
	4100	3600	310	515	410	945	6150	2650	2995	210	130	10	180	10600	11
C175	3100	2600	310	515	410	935	5150	2650	2950	180	130	10	180	9700	15
	3700	3200	310	515	410	945	5750	2650	2950	180	130	10	180	11350	15
	4100	3600	310	515	410	945	6150	2650	2995	180	130	10	180	11900	15
C220	3100	2600	310	515	410	940	5180	2650	2950	180	140	10	290	11300	18,5
	3700	3200	310	515	410	965	5780	2650	3040	180	140	10	290	12850	18,5
	4100	3600	310	515	410	965	6180	2650	3040	180	140	10	290	13650	18,5
	5100	4200	310	515	410	995	7180	2650	3090	180	140	10	290	17000	18,5
	6100	5100	310	515	410	995	8180	2650	3090	180	140	10	290	21700	18,5
C270	3100	2600	310	515	410	950	5200	2650	3040	150	120	10	290	13300	22
	3700	3200	310	515	410	955	5800	2650	3040	150	120	10	290	14500	22
	4100	3600	310	515	410	955	6200	2650	3040	150	120	10	290	15300	22
C320	3100	2600	310	535	410	955	5300	2655	3070	150	110	10	290	14700	22
	3700	3200	310	535	410	955	5750	2655	3080	150	110	10	290	15500	22
	4100	3600	310	535	410	955	6150	2655	3130	150	110	10	290	16800	22
	5100	4200	310	535	410	1045	7150	2655	3140	150	110	10	290	21500	22
	6100	5100	310	535	410	1065	8150	2655	3170	150	110	10	290	26000	22
C400	3100	2600	310	535	410	1015	5150	2685	3400	100	80	8	400	18700	30
	3700	3200	310	535	410	975	5750	2685	3400	100	80	8	400	20700	30
	4100	3600	310	535	410	985	6150	2700	3400	100	80	8	400	22500	30
	5100	4200	310	535	410	980	7150	2700	3400	100	80	8	400	25500	30
	6100	5100	310	535	410	1055	8150	2700	3600	100	80	8	400	33000	30
	8100	7100	310	535	410	815	10150	2785	3750	100	80	8	400	45000	30
C500	3700	3200	310	535	410	1035	5750	2735	3400	80	70	8	500	24100	37
	4100	3600	310	535	410	1025	6150	2740	3400	80	70	8	500	26300	37
	5100	4200	310	535	410	1055	7150	2750	3650	80	70	8	500	30000	37
	6100	5100	310	535	410	965	8200	2750	3900	80	70	8	500	39500	37
	8100	7100	310	535	410	750	10200	2750	4000	80	70	8	500	55500	37